

Powering an LED From Two (or More) Sources

It is possible to wire up an LED so it is lit from two sources of power.

My requirement was to have certain annunciators illuminated by both the actual system switching and also for a Test/Recall capability.

ian@737ng.co.uk



GENERAL DISCUSSION & OPTIONS.

You may not need the same requirement that I have, but this discussion just may help you with your own circuitry.

CONDITION – On the MIP/OVERHEAD/FIRE

PANEL and Glareshield there are so many warning and advisory Annunciators that firstly I wanted the capability to test them (for maintenance) and also during some of the Checklist Procedure, there is an item called Recall where certain CHECKS of Systems and Annunciators is made. That required an LED to be powered from 2 and even 3 sources.

SOLUTION By using diodes, you can effectively direct power anywhere in the circuit and prevent it from reaching other parts. A diode is basically a 'one way street' for power. It can travel in the direction of the arrowhead, but it cannot pass the straight line (I like to think of it as a 'brick wall').

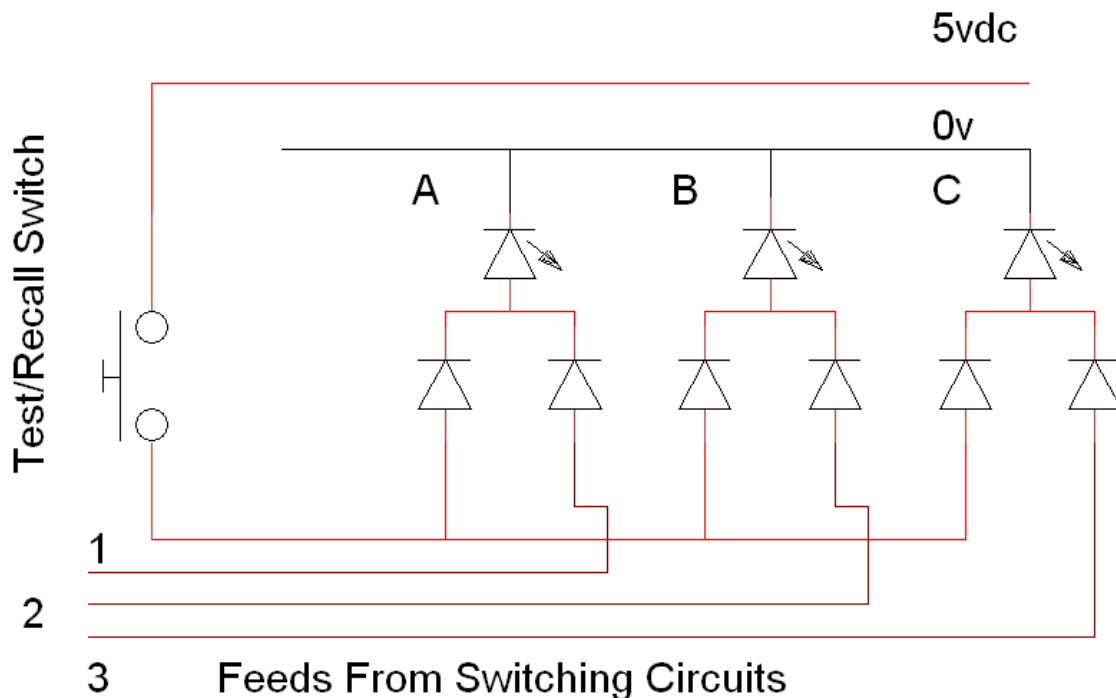

If you look at the above diagram, there are 3 LED's A,B & C. If the Test/Recall Button is pressed, power is allowed to flow to all 3 LED's and subsequently, they will all light up.

Now dealing with the Switching Circuits, if line 1 is supplied with power, only LED A will light.

If line 2 is supplied with power, only LED B will light. Finally if line 3 is supplied with power, only LED C will light.

The above diagram is purely for demonstration purposes. With some constructive wiring, you can reduce the number of wires and diodes dramatically. Using Diodes as your 'valves' it's also possible to feed the LED from as many sources as you need

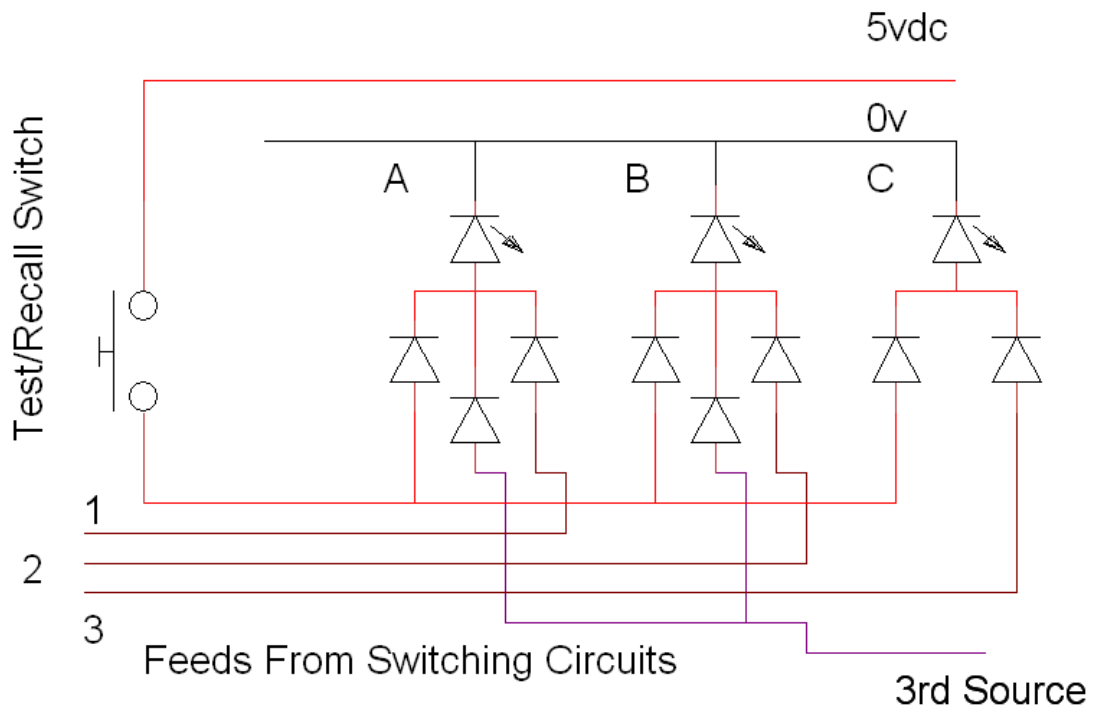

Now taking it a stage further, if the third source is powered up only LED A & B will light like on the Master Warning Panels on the Glareshield. And so on.